



City of Napoleon, Ohio

Zoning Department

255 West Riverview Avenue, P.O. Box 151

Napoleon, OH 43545

Kevin Schultheis Code Enforcement/ Zoning Administrator

Telephone: (419) 592-4010 Fax: (419) 599-8393

www.napoleonohio.com

RESIDENTIAL ZONING PERMIT

Issued Date: August 29, 2022

Expiration Date: August 29, 2023

Permit Number: P-22-165

Job Location: 1025 Woodlawn Ave.

Owner: Matthew Conroy
1025 Woodlawn Ave.
Napoleon, Ohio 43545

Contractor: Logan Hoover
Phone: 419-630-8995 (Lance Wyse)

Zone: R2- Low Density Residential Set Backs: Accessory Building
Front: 50 Rear: 10 Side: 7

Comments: New Garage

Permit Type: Zoning

Fee: \$25.00

Status: Paid

Amount Due: \$0.00

Kevin Schultheis
Code Enforcement / Zoning Administrator



City of Napoleon, Ohio P-22-165

Zoning Department

255 West Riverview Avenue, P.O. Box 151
 Napoleon, OH 43545
 Kevin Schultheis Code Enforcement / Zoning Administrator
 Telephone: (419) 592-4010 Fax: (419) 599-8393
 www.napoleonohio.com

Residential Zoning Permit Application

Date 8/29/22 Job Location 1025 WOODLAWN AVE

Owner MATTHEW CONROY Telephone # 419.630.8945

Owner Address 1025 WOODLAWN AVE

Contractor LOGAN HOOVER Cell Phone # _____

Description of Work to be Performed NEW GARAGE

Estimated Completion Date 2/28/23 Estimated Cost 28,000.00

Demo Permit - \$100.00 – See Separate Form	(MDEMO 100.1700.46690)	\$
Zoning Permit - \$25.00	(MZON 100.1700.46690)	\$ <u>25.00</u>
Fence/Pool/Deck - \$25.00	(MZON (100.1700.46690)	\$
Accessory Building 200 SF or less (Detached) - \$25.00	(MZON 100.1700.46690)	\$
Driveway/Sidewalk/Curbing/Patio - \$0.00	(MZON 100.1700.46690)	\$
Drainage Permit/Outside Water/Sewer Repair - \$0.00	(MBLDG 510.0000.44730)	\$
1" Water Tap, 5/8" Meter, Copper Setter and Transmitter - \$1,200.00(Outside City - \$5,680)	(MBLDG 510.0000.44730)	\$
1" Water Tap, 3/4" Meter, Copper Setter and Transmitter - \$1,300.00(Outside City - \$5,820)	(MBLDG 510.0000.44730)	\$
1" Water Tap, 1" Meter, Copper Setter and Transmitter - \$1,400.00 (Outside City - \$5,960)	(MBLDG 510.0000.44730)	\$
1" Meter, Copper Setter and Transmitter Without Tap - \$525.00	(MBLDG 510.0000.44730)	\$
3/4" Meter, Copper Setter and Transmitter Without Tap - \$440.87	(MBLDG 510.0000.44730)	\$
5/8" Meter, Copper Setter and Transmitter Without Tap - \$350.00	(MBLDG 510.0000.44730)	\$
Sewer Tap For Lots 7,200 Sq. Ft. Or Less - \$0.00	(MBLDG 520.0000.44830)	\$
Sewer Tap For Lots (Single Family) 7,201 To 12,199 Sq. Ft. (x \$0.012)	(MBLDG 520.0000.44830)	\$
Sewer Tap For Lots (Single Family) 12,200 Sq. Ft. or Greater - \$60.00	(MBLDG 520.0000.44830)	\$
Sewer Tap For Lots (Two Family) 7,201 to 23,866 Sq. Ft. (x\$0.012)	(MBLDG 520.0000.44830)	\$
Sewer Tap For Lots (Two Family) 23,867 Sq. Ft. or Greater - \$200.00	(MBLDG 520.0000.44830)	\$
Sewer Tap For Lots (Three Family) 7,201 to 36,366 Sq. Ft. (x\$0.012)	(MBLDG 520.0000.44830)	\$
Sewer Tap For Lots (Three Family) 36,367 Sq. Ft. or Greater - \$350.00	(MBLDG 520.0000.44830)	\$
Sewer Tap Inspection Fee For Single Family or Duplex - \$60.00	(MBLDG 520.0000.44830)	\$
Inspection Fee Outside the Corporation Limits - Increase 50%	(MBLDG 520.0000.44830)	\$
TOTAL FEE:		\$

I FULLY UNDERSTAND THAT NO EXCAVATION, CONSTRUCTION OR STRUCTURAL ALTERATION, ELECTRICAL OR MECHANICAL INSTALLATION OR ALTERATION OF ANY BUILDING STRUCTURE, SIGN, OR PART THEREOF AND NO USE OF THE ABOVE SHALL BE UNDERTAKEN OR PERFORMED UNTIL THE PERMIT APPLIED FOR HEREIN HAS BEEN APPROVED AND ISSUED BY THE CITY OF NAPOLEON ZONING DEPARTMENT.

I hereby certify that I am the Owner of the named property, or that the proposed work is authorized by the Owner of record and that I have been authorized by the Owner to make this application as his/her authorized agent and I agree to conform to all applicable laws of the jurisdiction. In addition, if a permit for Work described in this application is issued, I certify that the code official or the code official's authorized representative shall have the authority to enter areas covered by such permit at any reasonable hour to enforce the provisions of the code(s) applicable to such permit.

I HEREBY ACKNOWLEDGE THAT I HAVE READ AND FULLY UNDERSTAND THE ABOVE LISTED INSTRUCTIONS.

SIGNATURE OF APPLICANT: [Signature] DATE: 8/29/22

BATCH # 48268 CHECK # 716 DATE 8/30/22

Per Rule 10.2 of the City of Napoleon Rules for Water and Sewer Service, City personnel will assist property owners in locating existing sanitary sewer laterals and water services to the best of their ability. However, the City does not guarantee the accuracy of said markings and is not liable for any expense incurred by the property owner if said markings are incorrect.

LANCE R WYSE 06/15
MARIA S WYSE
130 N FRANKLIN ST.
WAUSEON, OH 43567

56-734/412

716

DATE

8/29/2022
PWP

© DELIVER DRINK COMPANIES
SECURITY WITH HIGH SECURITY



PAY TO CITY OF NAPOLEON

\$ 25.00

THE ORDER OF

TWENTY FIVE & 00/100

DOLLARS

Heat
Reactive
Ink



**FARMERS &
MERCHANTS**
STATE BANK
www.fm.bank

MEMO

J Wyse

MP

⑆041207341⑆ 2176798⑈ 0716

LOOK FOR FRAUD-DETECTING FEATURES INCLUDING THE SECURITY SQUARE AND HEAT-REACTIVE INK. DETAILS ON BACK.

CITY OF NAPOLEON UTILITY DEPARTMENT

Batch 48268
Sequence 21

Date 29 AUG 2022 Time 01:35PM

Account KZON
Name W CONROY
Document 1025 WOODLAWN

Pay Type GK
Refer 716

Amt Paid	25.00
Amt Tend	25.00
Change	0.00
100.1700.46690	25.00

1/4 in Ave

1250

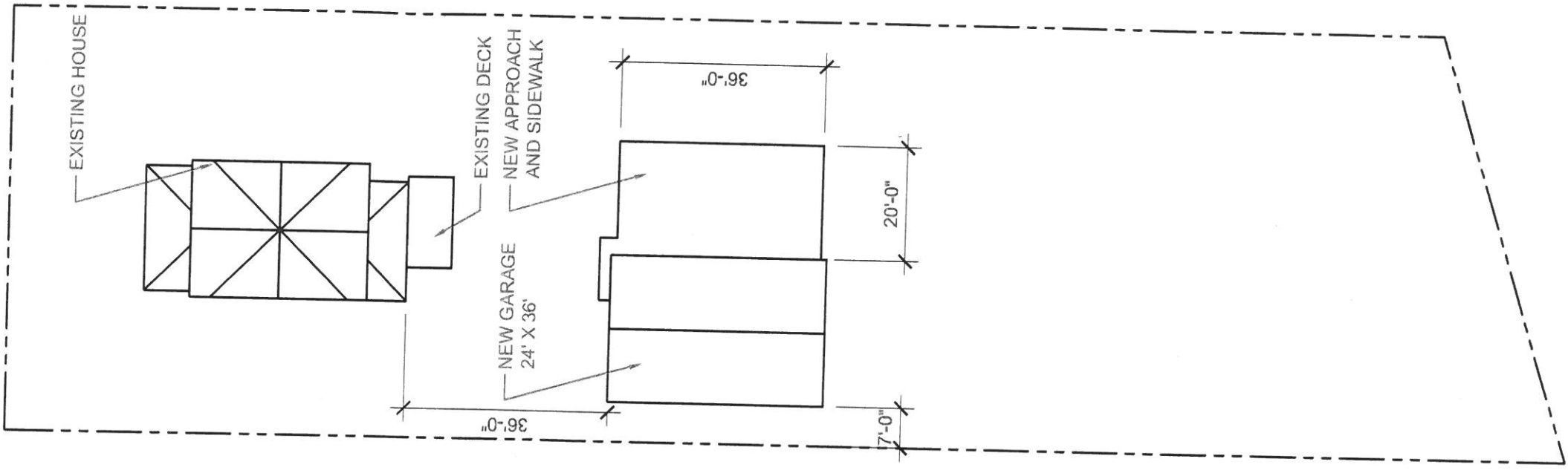

1250